

TWO HOLE FLANGE SHROUD 0.4MM

R222.450.321

LIMITED DETENT

Series : SMP

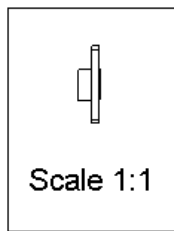
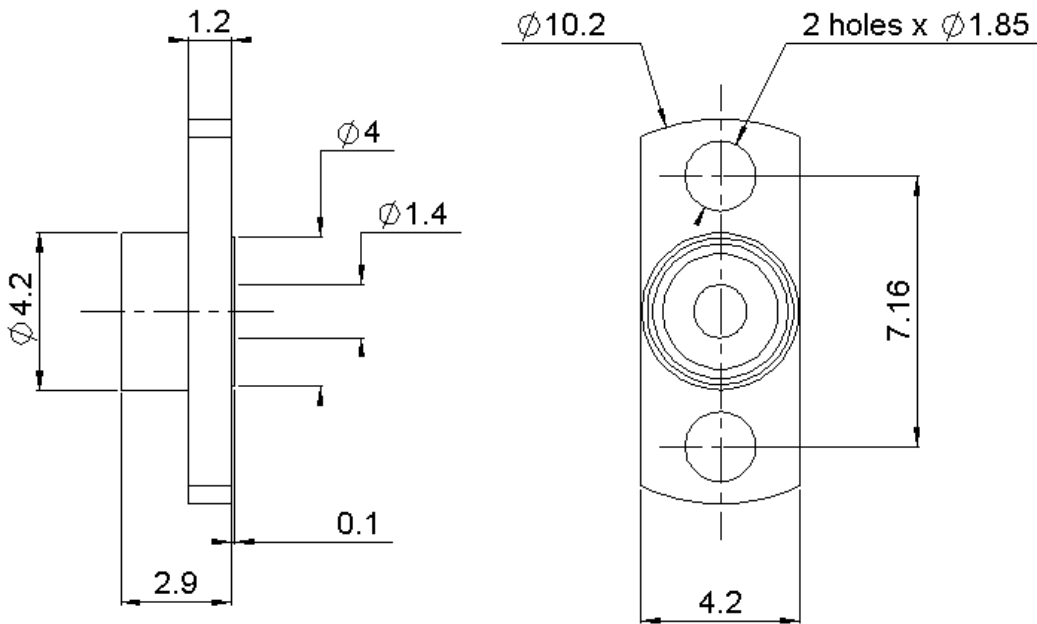

PANEL CUT OUT

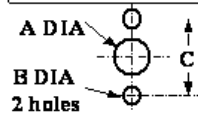

	mm	
	Maxi	mini
A	4.15	4.05
B	1.90	1.80
C	7.21	7.11

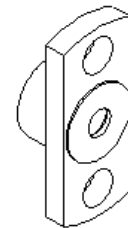

All dimensions are in mm.



COMPONENTS	MATERIALS	PLATINGS (µm)
BODY	STAINLESS STEEL	PASSIVATED .
CENTER CONTACT		
OUTER CONTACT		
INSULATOR		
GASKET		
OTHERS PARTS		
-	-	-
-	-	-

Issue : 0529 B

In the effort to improve our products, we reserve the right to make changes judged to be necessary.



TWO HOLE FLANGE SHROUD 0.4MM

R222.450.321

LIMITED DETENT

Series : SMP

PACKAGING

SPECIFICATION

Standard	Unit	Other
100	'W' option	Contact us

ELECTRICAL CHARACTERISTICS

ENVIRONMENTAL

Impedance		NA	Ω
Frequency		NA	GHz
VSWR	NA +	0.000	x F(GHz) Maxi
Insertion loss		NA	\sqrt{F} (GHz) dB Maxi
RF leakage	- (NA	- F(GHz)) dB Maxi
Voltage rating		NA	Veff Maxi
Dielectric withstanding voltage		NA	Veff mini
Insulation resistance		NA	M Ω mini

Operating temperature	-65/165	$^{\circ}$ C
Hermetic seal	NA	Atm.cm3/s
Panel leakage	NA	

OTHERS CHARACTERISTICS

Assembly instruction

Others :

MECHANICAL CHARACTERISTICS

Center contact retention			
Axial force – Mating end	NA	N	mini
Axial force – Opposite end	NA	N	mini
Torque	NA	N.cm	mini
Recommended torque			
Mating	NA	N.cm	
Panel nut	NA	N.cm	
Mating life	500	Cycles	mini
Weight	0.336	g	

Issue : 0529 B

In the effort to improve our products, we reserve the right to make changes judged to be necessary.



TWO HOLE FLANGE SHROUD 0.4MM**LIMITED DETENT****R222.450.321**

Series : SMP

**ADDITIONAL INFORMATIONS
MOUNTING INSTRUCTIONS**

1. Check the quality of the soldering, as well as the position of the glass seal in the package.

- 2.

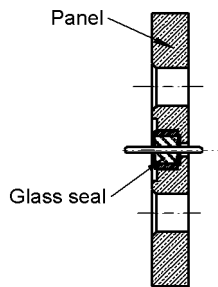

Place the receptacle and pre-assemble screw on the package.

Mount the aligning positioner R2821.860.022 into the flange to ensure a good concentricity.

Screw the receptacle on the package.

Remove the aligning positioner.

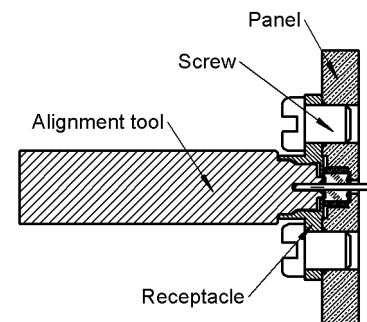

Issue : 0529 B

In the effort to improve our products, we reserve the right to make changes judged to be necessary.

